

# TG2625FCS-P

**2.6mm F2.5**  
**for 1/3 type Cameras, Pinhole**  
**CS-Mount**

with Focus, w/o Amplifier

**1/3**  
type

Model No.	TG2625FCS-P		Effective	Front	Ø2.2mm
Focal Length	2.6mm		Lens Aperture	Rear	Ø11.5mm
Max. Aperture Ratio	1:2.5		Back Focal Length	14.1mm	
Max. Image Format	4.8mm x 3.6mm(Ø6mm)		Flange Back Length	12.5mm	
Operation Range	Iris	F2.5 - F360C	Mount	CS-Mount	
	Focus	0.2m - Inf.	Filter Size	—	
Control	Iris	DC Auto Iris	Dimensions	Ø34.5mm x 39.8mm x 73.5mm	
	Focus	Manual	Weight	82g	
Object Dimension at M.O.D.	35.5cm x 26.7cm				
Angle of View	D	1/3 type	96.0°	1/4 type	79.6°
	H		83.2°		67.5°
	V		67.5°		53.2°
Coil	Drive	190Ω			
	Control	855Ω			
Operating Temperature	-20°C - +50°C				

M.O.D. : Minimum Object Distance

**CS**

## Dimensions

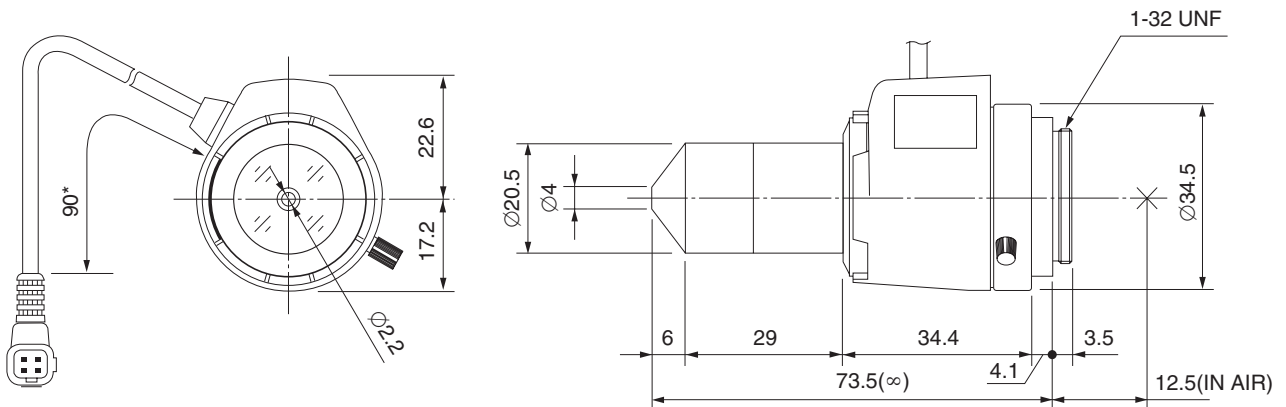

\* : 310mm cable is available

## Wiring Diagram

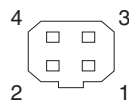

### Pin No.

1	BROWN	Control (-)
2	RED	Control (+)
3	YELLOW	Drive (+)
4	ORANGE	Drive (-)