

License Plate Capture Camera

INSTRUCTION MANUAL

Version Date: 11/9/11



Please read this manual carefully before installation and operation of the product.

Dear Customers!

By selecting this product, you have decided to use a professional device that guarantees highest quality and reliability. We would like to thank you very much for your confidence and kindly ask you to read the following instructions carefully before installation and operation in order to take full advantage of all quality features regarding this product.

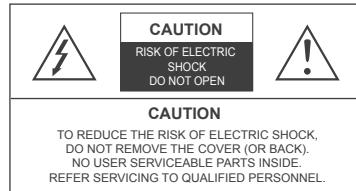

The lightning flash with an arrowhead symbol, within an equilateral triangle is intended to alert the user to the presence of uninsulated dangerous voltage within the product's enclosure that may be of sufficient magnitude to constitute a risk of electric shock to persons.



The exclamation point within an equilateral triangle is intended to alert the user to the presence of important operating and maintenance (servicing) instructions in the literature accompanying the appliance.

INFORMATION

This equipment has been tested and found to comply with limits for a Class A digital device, pursuant to part 15 of the FCC Rules. These limits are designed to provide reasonable protection against harmful interference when the equipment is operated in a commercial environment. This equipment generates, uses, and can radiate radio frequency energy and, if not installed and used in accordance with the instruction manual, may cause harmful interference to radio communications. Operation of this equipment in a residential area is likely to cause harmful interference in which case the user will be required to correct the interference at his own expense.

WARNING

Changes or modifications not expressly approved by the manufacturer could void the user's authority to operate the equipment.

CAUTION – To prevent electric shock and risk of the fire hazards

- Do NOT use power source other than that specified.
- Do NOT expose this appliance to rain or moisture.

This installation should be made by a qualified service person and should conform to all local codes.

Table of contents

1. Precautions	4
2. Limitation of liability	5
3. Disclaimer of warranty	5
4. Package	6
5. Installation	7-9
5-1. How to mount to Ceiling	
5-2. How to install to Wall	
5-3. 3-Axis adjustment	
5-4. Rear Hole Plugs	
6. Overview	10
7. Main Features	10~11
8. Troubleshooting	12
9. Specifications	13
10. Dimension	13

1. Precautions

- Please read the manual carefully before the installation in order to make use the camera to be set up correctly and to have the best picture quality.
- Please keep the manual in good condition for your future reference and service application.
- Installation and services should only be carried out by an authorized personnel according to local safety regulations.
- If any liquid or solid matter gets into the housing, immediately disconnect the camera from power supply and have it checked by your authorized dealer before reusing.
- Avoid installing the camera at extremely hot or cold places.
- If you are not a certified person, never try to dismantle the camera. To avoid electric shock, never remove the screws or covers. There are no parts inside that need maintenance by the user. All maintenance should be carried out by qualified personnel.
- Avoid installing the camera at a place of high humidity.
- Avoid installing the camera at the place exposed to gas or oil.
- Keep the top glass of the lens always clean in order to obtain the best picture quality all the time. Be careful not to be stained by fingerprint.
- Don't face the camera directly toward sunlight or sunlight reflecting area. CCD may go defective at this condition.
- Please give a special attention to keep the unit from dangerous drop or external shock during the process of transportation or handling.
- Never try to touch the camera in wet hand. It may cause an electric shock.
- Do not expose the camera to radioactivity. It causes a serious damage on the CCD.
- Install away from electric or magnetic fields.

2. Limitation of liability

This publication is provided "AS IS" without warranty of any kind, either express or implied, including but not limited to, the implied warranties of merchantability, fitness for any particular purpose, or noninfringement of the third party's right. This publication could include technical inaccuracies or typographical errors. Changes are added to the information herein, at any time, for the improvements of this publication and/or the corresponding product(s).

3. Disclaimer of warranty

In no event shall seller be liable to any party or any person, except for replacement or reasonable maintenance of the product, for the cases, including but not limited to below :

- (1) Any damage and loss, including without limitation, direct or indirect, special, consequential or exemplary, arising out of or relating to the product;
- (2) Personal injury or any damage caused by inappropriate use or negligent operation of the user;
- (3) unauthorized disassemble, repair or modification of the product by the user;
- (4) Inconvenience or any loss arising when images are not displayed, due to any reason or cause including any failure or problem of the product;
- (5) Any problem, consequential inconvenience, or loss or damage, arising out of the system combined by the devices of third party.
- (6) Any claim or action for damages, brought by any person or organization being photogenic subject, due to violation of privacy with the result of that surveillance-camera's picture, including saved data, for some reason, becomes public or is used for the purpose other than surveillance.

4. Package



License Plate
Capture Camera 1EA



Instruction manual
1EA

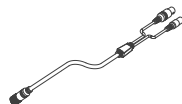

Power + Video Cable
1EA



Mounting screws
3EA



Plastic anchor
3EA

5. Installation

5-1. How to mount to Ceiling

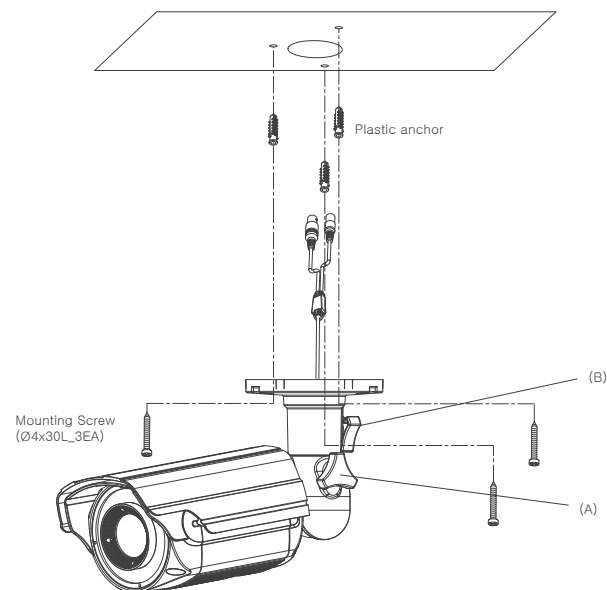

- ① Drill three screw holes on the ceiling plate to fix three plastic anchors (supplied) in the holes.
- ② Fix the plastic anchors in the holes.
- ③ Position the mounting bracket on the screw points.
- ④ Fix the mounting bracket by tightening the screws.
- ⑤ Slightly loosen knob (A) then adjust tilt(180°) and rotation(360°) of the camera and tighten the knob firmly.
- ⑥ Slightly loosen knob (B) then adjust pan(360°) of the camera and tighten the knob firmly.